

OWNER'S MANUAL
LOCK-N-LOAD®
RIFLE BULLET FEEDER
30 CAL
CONVERSION KIT

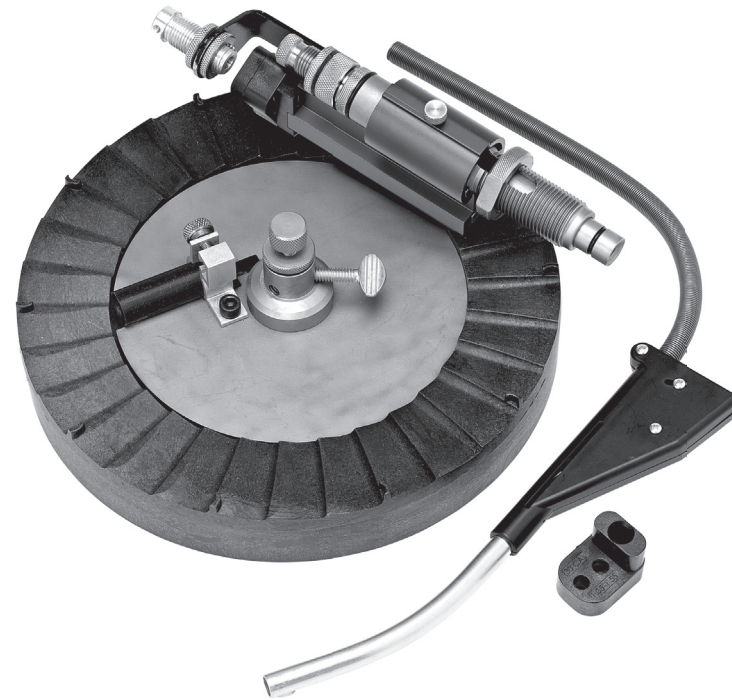

30 Cal. Feed Plate Conversion Kit

Item No.	Part No.	Qty.	Description
1	399213	1	Tube Spring Clamp
2	399210	1	Button Head Cap Screw (BCHS), 10-32 x 1/4
3	392011	1	Hex Nut, 10-32
4	399209	1	Steel Knurled Thumb Screw
5	399354	1	Bullet Drop Funnel, 30 Cal.
6	399205	1	Screw Adjustment Bullet Feed
7	399206	1	Screw Lock Nut Adjustment
8	398067	1	Rubber Washer
9	399208	1	Center Plate Adjustment Nut
10	398400	1	Thumb Screw, 1/4-20 x 1
11	399356	1	Hopper Turning Plate, 30 Cal.
12	398401	2	Flat Head Cap Screw (FHCS), 10-32 x 3/8
13	399352	1	Bullet Feeder Wheel, 30 Cal.

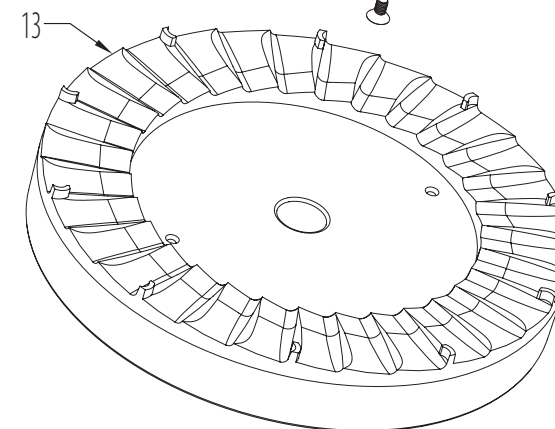
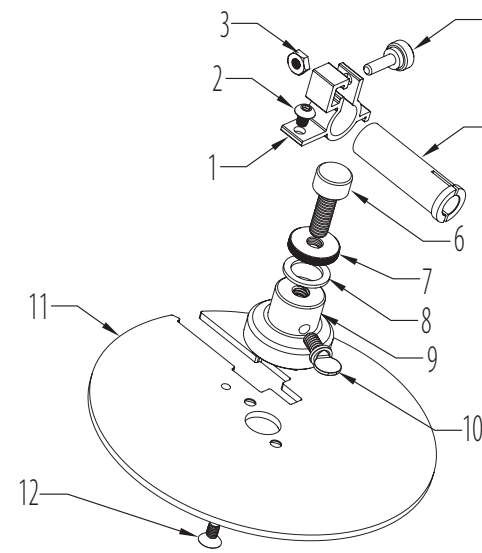

Rifle Bullet Feeder Die

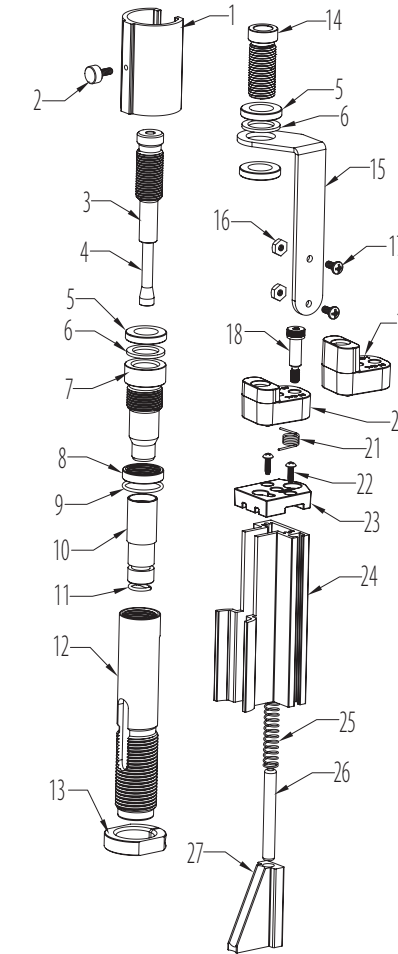

Item No.	Part No.	Qty.	Description
1	399327	1	Feeder Clamp, RBF
2	69006	1	Thumb Screw, 6-32 x .40
3	399322	1	Seat Adjust Screw, RBF
4	399326	1	Seating Stem, 30 Cal., RBF
5	044800	3	Seat Adjust Lock Ring
6	398067	2	Rubber Washer
7	399320	1	Crimp Adjust Screw, RBF
8	398906	1	Crimp Adjust Lock Ring
9	480083	1	Crimp Adjust Locking O-Ring
10	399324	1	30 Cal Alignment Sleeve, RBF
11	399371	1	Bullet Retaining O-Ring, RBF
12	399321	1	Die Body, RBF
13	044000	1	Lock Ring
14	399341	1	Feed Tube Retainer, 30 Cal, RBF
15	399339	1	Feed Support Bracket, Black
16	392452	2	Hex Nut, 6-32
17	399340	2	Pan Head Screw, 6-32 x 5/16
18	399336	1	Shoulder Bolt, 1/4 x 5/8 10-24
19	399335	1	Feed Block, 30 Cal Long
20	399334	1	Feed Block, 30 Cal Short
21	399337	1	Torsion Spring, 1/4"
22	399167	2	Pan Head Thread Cut, 4-40 x 3/8
23	399331	1	Feeder Cap
24	399328	1	Feeder Body
25	399338	1	Compression Spring, 1/4"
26	399330	1	Dowel Pin, 1/4 x 2
27	399329	1	Bullet Ramp

Switch Retainer Assembly

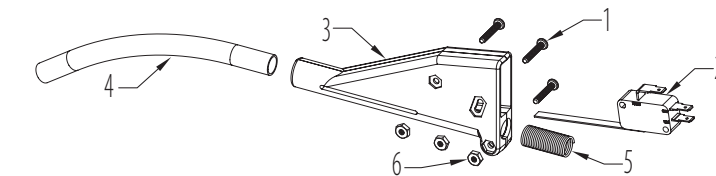

Item No.	Part No.	Qty.	Description
1	399347	3	4-40 x 11/16 Pan Head Screw
2	399364	1	Micro Switch (Cherry D42LR1XL)
3	399345	1	Switch Retainer, 30 Cal
4	399344	1	Feed Tube, 30 Cal
5	399350	1	Feed Spring, 30 Cal
6	392458	3	4-40 Hex Nut



P.O. Box 1848, Grand Island, Nebraska 68802-1848
 308-382-1390 • 800-338-3220 • Fax: 308-382-5761
 www.hornady.com • Hornady.com/contact_us



1 Remove 22 Caliber Bullet Feed Die

Remove the 22 caliber bullet feed die from your press. Remove any bullets from inside the die before storing it.

NOTE: If using the Lock-N-Load® bushing system, your die will be set for the next use.

2 Remove Feed Spring

Loosen the thumb screw to disconnect the 22 caliber feed spring from the drop funnel. Remove the 22 caliber feed spring and switch assembly.

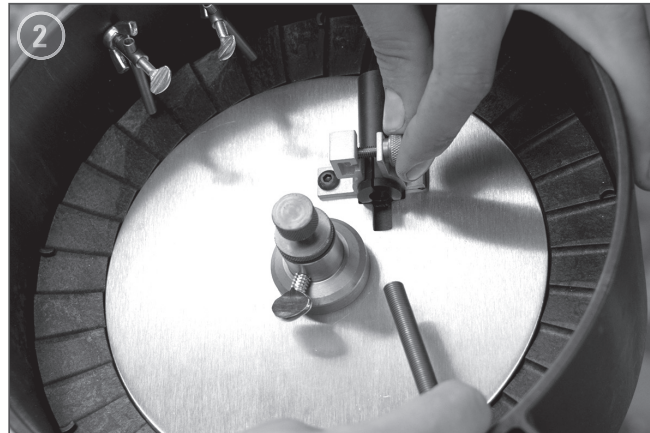

3 Empty 22 Caliber Bullets

Remove all bullets from the hopper.

4 Remove 22 Caliber Bullet Guide Plate

Loosen the thumb screw and slide the 22 caliber Bullet Guide Plate out of the hopper.



5 Remove 22 Caliber Feed Wheel

Rotate the wipers to the side and slide the 22 caliber Feed Wheel out of the hopper.

NOTE: Use two small hex wrenches or two ¼-20 bolts to lift the Feed Wheel out of the hopper.



6 Set Up 30 Caliber Feed Wheel

Place the 30 caliber Feed Wheel and 30 caliber Bullet Guide Plate in the hopper.



7 Set Up 30 Caliber System

Use the same steps found in the 22 caliber Rifle Bullet Feeder manual for further setup and adjustment.

*These instructions are also available online at hornady.com/manuals.

Keep in mind the following information:

Bullets

- Use pointed bullets (spire point, polymer tip, hollow point, etc.) **The rifle bullet feeder does not feed round nose or flat point bullets.**

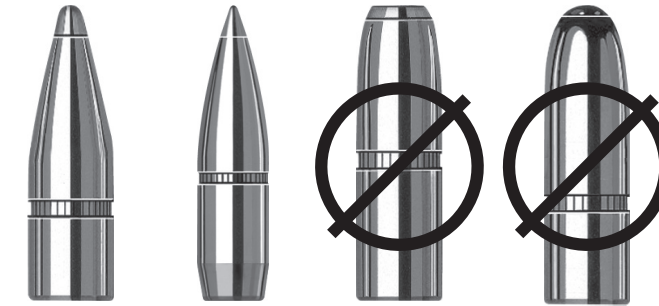

- Bullet lengths from approximately .80" to 1.05" will use the short feed block. Bullet lengths from approximately 1.05" to 1.55" will use the tall feed block. **Do not use bullets outside this range.**

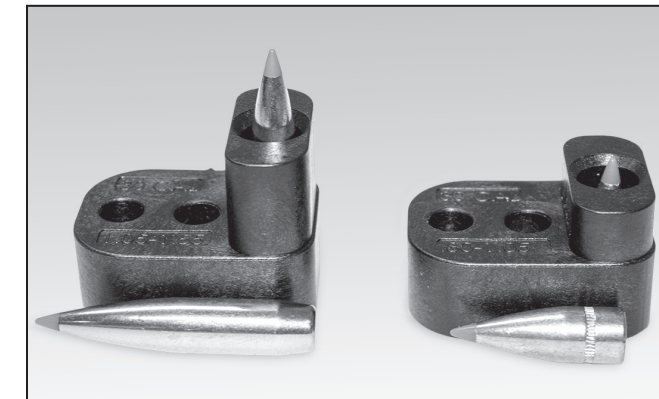

Case Lengths

- The 30 caliber rifle bullet feeder will feed, seat, and crimp rifle cases from 1.82" to 2.85" in length (300 Savage to 300 Rem Ultra Mag) in a Hornady® press.